

TRADE\$AVE

100, 150 & 200W LED Floodlights

NEW



Features

- Aluminium housing powder coated black
- Tempered glass lens & polycarbonate cover
- Slim body design
- Constant current driver
- Surge protected 6kV Line-Line, 10kV Line-Earth
- High efficiency SMD chip 125Lm/w
- Operating Temp: -30°C to +50°C
- IP66 rated at IK08 impact resistance

Includes

- Prewired 1.5m 3 core cable

CERTIFICATION	IP RATING	DALI DIMMABLE
PROTECTION	IK RATING	BOX CTN QTY
		1 1

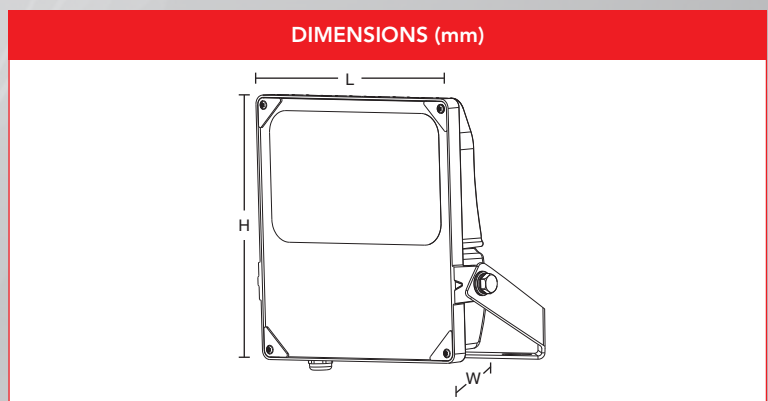

Part No.	Voltage AC	Watt	PF	CCT	Ra	Lumens	Beam Angle	Lifetime hrs	Fitting Colour	Dimensions (L x W x H) mm	Weight
TSFL100W	200-240V	100W	0.95	5000K	70	12,500	120	63,000	Black	314 x 269 x 61	2.8kg
TSFL150W	200-240V	150W	0.95	5000K	70	18,750	120	63,000	Black	360 x 302 x 67	3.9kg
TSFL200W	200-240V	200W	0.95	5000K	70	25,000	120	63,000	Black	398 x 343 x 70	5.3kg

1300 555 586
repelec.com.au



@RepelecAU