

# TRADE\$AVE

## 30, 50 & 150W LED Street Lights

**IPART  
APPROVED**  
EXCEPT TSSL30WB



### ■ Features

- ❑ Aluminium housing powder coated black
- ❑ Tempered glass & polycarbonate optical lens
- ❑ Smooth body does not accumulate dust, sand or other solid material
- ❑ Pole mount with 60mm ø spigot
- ❑ Surge protection 6kV Line-Line, 12kV Line-Earth
- ❑ High efficiency SMD chips - 130Lm/w
- ❑ Operating temp: -30°C to +50°C
- ❑ IP66 rated

CERTIFICATION	IP RATING	DIMMABLE
PROTECTION	IK RATING	BOX   CTN QTY
		<b>1   1</b>

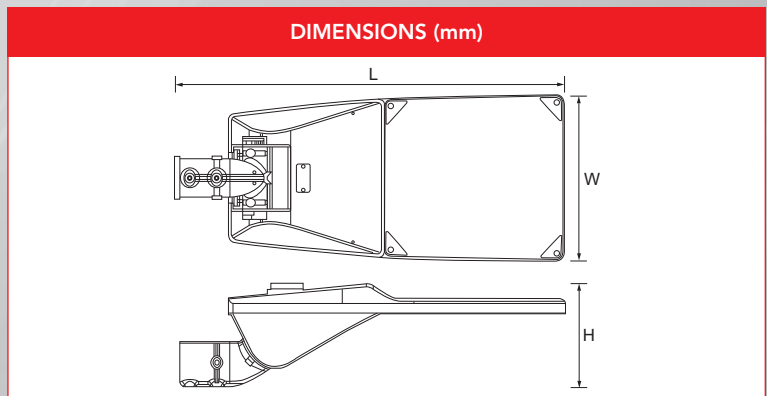

Part No.	Voltage AC	Watt	PF	CCT	Ra	Lumens	Beam Angle	Lifetime hrs	Fitting Colour	Dimensions (L x W x H)mm
TSSL30WB	200-240V	30W	>0.9	4000K	70	4,300	110°	100,000	Black	649 x 272 x 179
TSSL50WB	200-240V	50W	>0.9	4000K	70	6,500	110°	100,000	Black	649 x 272 x 179
TSSL150WB	200-240V	150W	>0.9	4000K	70	22,500	110°	100,000	Black	770 x 309 x 240

**1300 555 586**  
 **repelec.com.au**



**@RepelecAU**