

TRADE\$AVE

NEW



150W LED Street Light



Features

- Aluminium housing powder coated black
- Tempered glass & polycarbonate optical lens
- Smooth body does not accumulate dust, sand or other solid material
- Pole mount with 60mm \varnothing spigot
- Surge protection 6kV Line-Line, 10kV Line-Earth
- High efficiency SMD chips - 150Lm/w
- Operating temp: -30°C to +50°C
- IP66 rated

IPART APPROVED

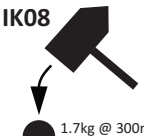
CERTIFICATION	IP RATING	DIMMABLE
		
IK RATING	BOX CTN QTY	
 1.7kg @ 300mm	1 1	

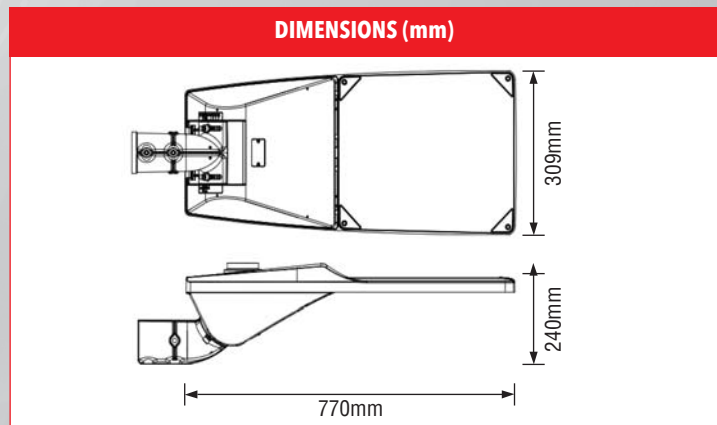

Part Number	Voltage VAC	Watt	PF	CCT	Ra	Lumens	Beam Angle	Lifetime hrs	Fitting Colour	Dimensions (L x W x H)mm
TSSL150WB	100/277V	150W	0.9	4000K	70	22,500	100°	50,000	Black	770 x 309 x 240

 **1300 555 586**
 **repelec.com.au**

rep ELEC
TRADE SOLUTIONS



@RepelecAU