

TRADE\$AVE

LED Street Light



Features

- Aluminium housing powder coated black
- Tempered glass & polycarbonate optical lens
- Smooth body does not accumulate dust, sand or other solid material
- Pole mount with 60mm ø spigot
- Surge protection 6kV Line-Line, 12kV Line-Earth
- High efficiency SMD chips - 130Lm/w
- Operating temp: -30°C to 50°C
- IP66 rated

DIMMABLE



CERTIFICATION



IP RATING



IK RATING

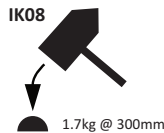

DIMENSIONS (mm)

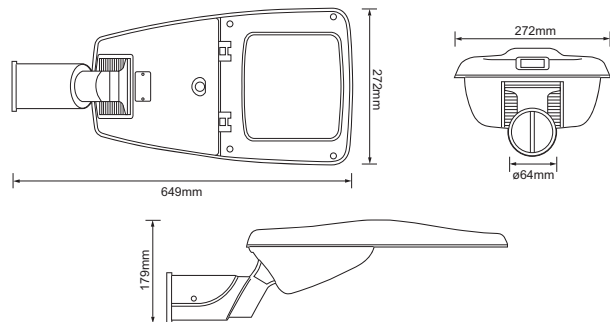

Part No.	Voltage VAC	Watt	PF	CCT	Ra	Lumens	Beam Angle	Lifetime hrs	Fitting Colour	Dimensions (L x W x H)mm
TSSL50WB	100/277V	50	0.9	4000K	70	6500	100°	200,000	Black	649 x 272 x 179

Part No.	Model No.	VEET Status	IPART Status
TSSL50WB	ST10-050	Pending	Pending

1300 555 586
repelec.com.au



Facebook Twitter @RepelecAU